

## Famoso 1000: Short Form Programming Guide

### General description (standard hard-wired unit)

The Famoso 1000 is a battery-powered, digital timer / thermostat. This unit can be pre-programmed to provide day-time temperature control, and night set-back temperature control. Each day can be programmed with the same – or different – time sequences of day time / night time temperature periods. Once the programme is running, the unit can be temporarily or permanently overridden to increase or decrease the desired temperature setting. Use only good quality AA size alkaline batteries, which should run the unit for approximately 18 months to 2 years (actual running time dependent on the way the unit is programmed, number of switching operations etc.). When the batteries need replacing, a low battery symbol flashes in the display.



### Fitting instructions (standard hard wired unit)

Fit the removable backplate to the wall, and connect live in / live out to the two screw terminals which are accessible under the removable cover. The order of connection does not matter as the terminals simply connect to a normally open switch. If replacing a conventional room-thermostat, and there is a neutral wire, this should **not** be connected to the Famoso 1000, but should be 'made safe' by taping up, or by 'parking' in a separate screw terminal connector. Now clip the Famoso 1000 body to the backplate, and you are ready to set the time and the programme you require. *Famoso 1000 RF needs no wiring – see supplementary information leaflet.*

### Programming (standard unit and RF version)

**Set the time** – when the batteries are first inserted, the full display is visible for approx. 3 seconds, then the clock symbol and hour (reading 12) flash. Press + or – button to change the hour, once this is correct, press ok. Now press + or – to change the minute, then press ok again. Press + or – to change the weekday to the current day (1 = Monday, 7 = Sunday), then press ok again. Press + or – to set your desired day-time temperature level, then press ok. Press + or – to set the desired night set-back temperature, and press ok.

**Set the programme** – after completion of setting time, day, then day and night temperatures, you can now programme the 'profile' of day and night temperatures for each 24 hour period of each day. You can choose from four pre-set programmes – please see the table below. Press the + or – button to scroll through the options from P1 to P4, and then press ok to select for that day. The programmes are presented automatically beginning with Monday, and with each press of the ok button, you move to the next day of the week.

| Programme | Day temperature operative between: | Night temperature operative between: |
|-----------|------------------------------------|--------------------------------------|
| P1        | 07:00 – 23:00                      | 23:00 – 06:59                        |
| P2        | 06:00 – 09:00 and 17:00 – 22:00    | 09:00 – 16:59 and 22:00 – 05:59      |
| P3        | 24 hours                           | No night temperature period          |
| P4        | No day temperature period          | 24 hours                             |

### Setting your own programme

If you wish to set your own timed sequence, press + or – until you see Pd in the display. Press ok and 0:00 appears in the display. Press the – button (which also has a moon ☾ symbol printed next to it) repeatedly, and you are programming in 30 minute increments – starting from midnight on the day in question – the night set-back temperature level. Once you reach the time in the morning when you wish to have day-time temperature control, start pressing the + button (which also has a sun ☀ symbol printed next to it). You will now be programming the day-time temperature level in 30 minute increments, and you will begin to see the graphic symbol at the bottom of the display representing this sequence. If you require a return to night set-back level from mid-morning until later in the day, again press the - / ☾ button repeatedly, and you are programming night set-back temperature in 30 minute increments. Using the - / ☾ and + / ☀ buttons, complete your day-time and set-back temperature sequence for the day, and press the ok button. The display shows the next day, and you can – once again – select with + or – buttons, P1 to P4, as well as Pd. Pd selection will now show the sequence you programmed earlier, so that you can simply accept a repeat of this sequence if required, or starting from 0:00 on the day in question, use the - / ☾ and + / ☀ buttons if you wish to programme a different timed sequence of day-time and set-back temperature periods.

### Manual override

Once programming is complete (having finished the programme for day 7 and pressed ok), the Famoso 1000 goes into automatic mode, and will now control according to the sequence just programmed. You can select continuous day-time or night set-back temperature by pressing the top button on the keypad – the operating mode button. Please see the instruction booklet supplied for a full explanation of the operating modes. Alternatively, you can temporarily override the temperature – up or down – by pressing the + or – key. In automatic mode, this will (until the next programmed sequence) adjust the set temperature up or down to the desired level. The hand symbol shows in the display, indicating this setting will self-reset with the next timed function. At any time you can restore automatic operation by pressing the ok button.

## Famoso 1000 RF: Supplementary information

### General description

The Famoso 1000 is a battery-powered, digital timer / thermostat. This unit can be pre-programmed to provide day-time temperature control, and night set-back temperature control. Each day can be programmed with the same – or different – time sequences of day time / night time temperature periods. Once the programme is running, the unit can be temporarily or permanently overridden to increase or decrease the desired temperature setting. Use only good quality AA size alkaline batteries, which should run the unit for approximately 18 months to 2 years (actual running time dependent on the way the unit is programmed, number of switching operations etc.). When the batteries need replacing, a low battery symbol flashes in the display.

### Commissioning newly installed transmitter & receiver:

The RF (radio frequency) version of this product, communicates with a receiver unit via radio waves, to switch the heating system on and off. Fit the receiver adjacent to the heating load to be controlled, and wire the receiver according to the internal diagram (see below). Connect 230v 50Hz supply to the unit. Now proceed with commissioning of transmitter & receiver. Commissioning of the unit is an essential but straightforward process.

Press and hold the button at the side of the receiver. Within the first two seconds the receiver LED flashes twice. Release the button. The LED will remain illuminated.

Now put the transmitter in continuous radio operation mode (see also page 22 of transmitter booklet): press and hold the top and bottom buttons of the transmitter at the same time. After a two-second delay, the unit will go into Ed (cycle pre-set) mode. Now press the ok button twice. The display will show “Fu on”(\*), and the transmission symbol  will flash for approx 0.5 seconds every 5 seconds. The transmitter is now in continuous radio operation system mode. As soon as a radio link is established with the receiver, the receiver's LED will go out. Coded radio communication is now established between transmitter and receiver, which is secure against interference radio noise, or communications from other similar devices. The transmitter can now be positioned in a suitable location for temperature sensing to control the heating system (typically the hallway, landing, or living room). Once the transmitter is in position, check for radio reception by the receiver (the LED flashes momentarily whenever a radio telegram is received). When locating the transmitter with respect to the receiver, you should note that steel reinforced walls, or any large metallic objects – for instance kitchen appliances, filing cabinet and mirrors – can deflect or block radio frequency signals. The transmission range in open air is approximately 50 metres, and this can reduce to between 20 and 30 metres in buildings, depending on radio ‘obstructions’.

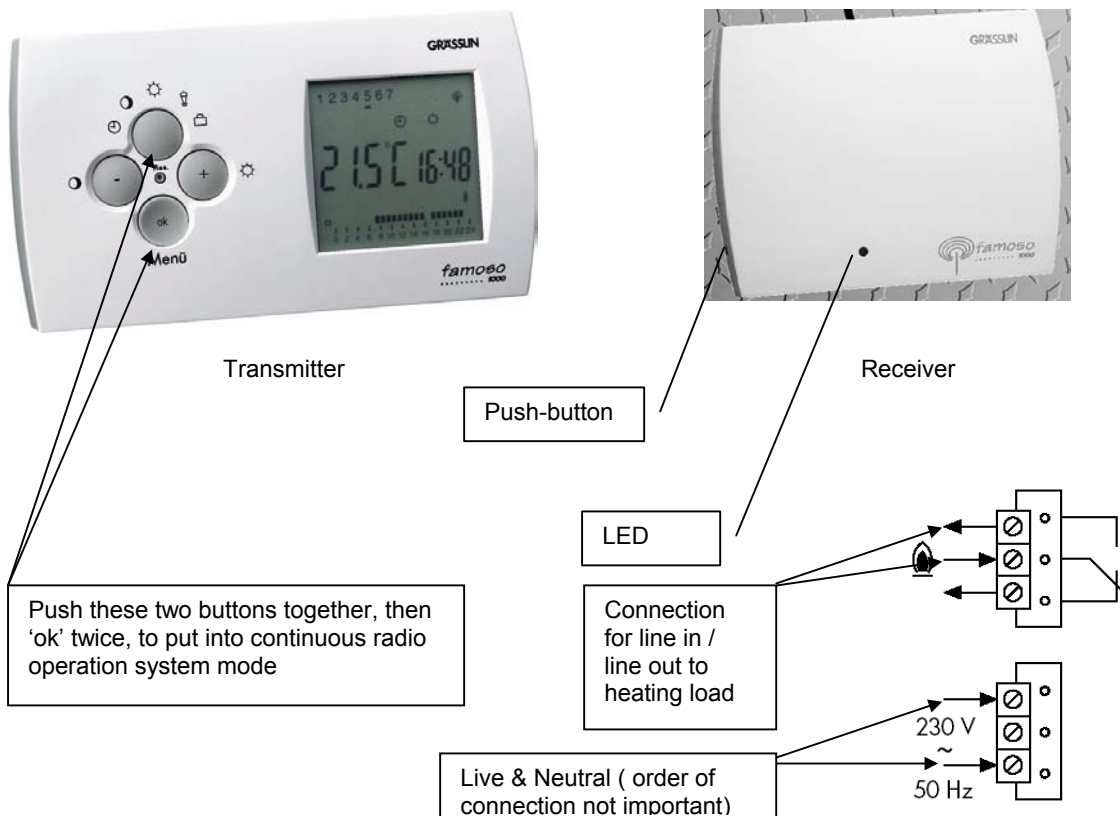

## Famoso 1000 RF - wiring

### Connection for mains-switching applications:

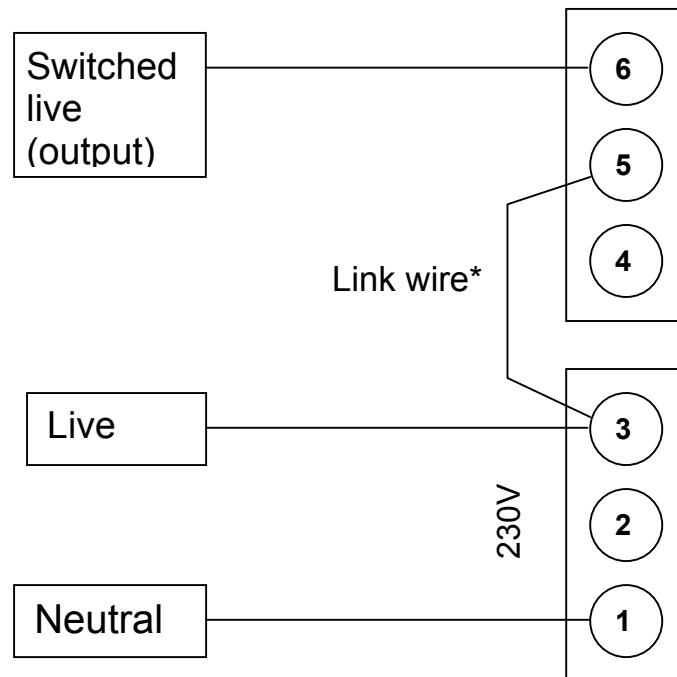

A link-wire should be fitted when the load requires a mains-input. See below for alternative connection using volt-free switching

---

### Connection for low-voltage switching applications:

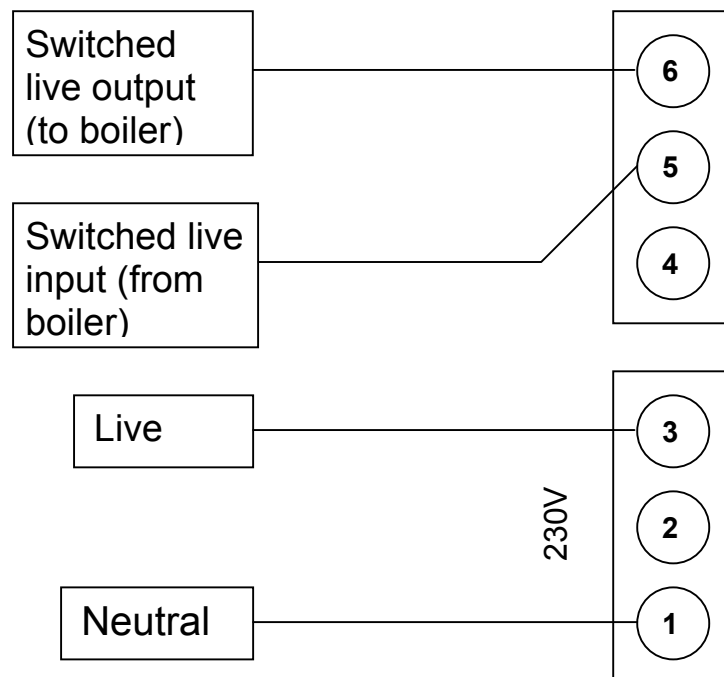

For non-mains switching do not fit a link wire.  
Connect terminals 5 and 6 to the boiler 'switched live out' & 'switched live in' terminals.