



PRODUCT DATA SHEET

**High Efficiency Central Heating Canned-Motor Pump**

**Stock code: APUMP+**



**Features:**

**ERP Compliant**

**E.E.I. < 0.23**

**Energy efficient:**

**Auto-adapts 5—45W**

**Low noise level < 43dB(A)**

PRODUCT SPECIFICATION

The APUMP+ is a high-efficiency permanent magnet canned-motor central heating pump, for circulation of the primary water in a domestic heating system.

Equipped with a differential pressure controller, the APUMP+ (when in auto setting) continuously adjusts its power input according to system load, to match the pump power to the system requirement.

Alternatively, if required the installer or user can set the pump on a constant speed setting, between Min—Max levels.

**Specification:**

Dimensions: 130 x 130 x 128mm

Connection: 1.5" BSP threaded flange

Output: Max. 6m head

Power: Auto-adjusting, 5—45 Watts

Noise level: < 43 dB(A)

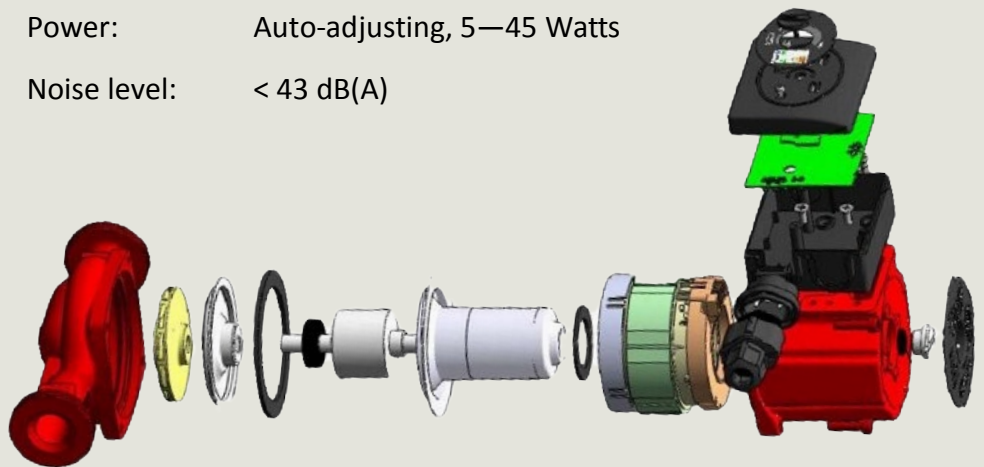

**TFC GROUP LLP**



Cert No: RS 30178  
QR057

TFC GROUP LLP, TOWER HOUSE, VALE RISE, TONBRIDGE, KENT TN9 1TB

Tel: 01732 351680 Fax: 01732 354445 www.tfc-group.co.uk

Prepared for TFC Group LLP By: M. Edmonston

Issue 1: July 2018

Page 1 of 1